



# USER MANUAL

## FORMART<sup>®</sup> 2 SMART VACUUM FORMER



# Thank you for choosing FORMART

Please read and follow the below **SAFETY** instruction before START



Do not install or operate the machine before reading these instructions carefully.

Turn the machine off and disconnect the AC plug when not in use.

Do not allow the power cord to hang (e.g., over the edge of a table or counter) or place/run the power cord under rugs, carpeting, or in high-traffic areas where it may be tripped over or pulled.

Do not use FORMART near gasoline, paint, or flammable liquids, as there may be a risk of fire or explosion.

Only use FORMART for vacuum forming. It is not intended for any other purpose.

## **\*\*Important:\*\***

To prevent the risk of fire, it is crucial that the vacuum forming machine is only operated under supervision. This precaution is especially important when the machine is being used by children, but it applies to all users.

- Supervised Operation: Always ensure that the machine is used under the supervision of a responsible adult.
- Child Safety: Children should not operate the machine without adult supervision.
- Fire Prevention: Proper supervision helps to promptly address any potential issues that could lead to fire hazards.



## **Fire**

Parts of this machine can reach temperatures greater than 280°C. DO NOT STACK ANY ITEMS ON TOP OF FORMART. There may be a risk of fire.



## **Injury from Trapping**

There is a risk of trapping fingers when loading plastic or pull the top/bottom frames. Ensure that appropriate care is taken to prevent trapping and use suitable personal protection.

# Safety

---

## **Electric Shock**

Never attempt any repair unless the ELECTRICAL SUPPLY IS DISCONNECTED. Only switch ON when all covers have been replaced.

## **Toxic Fume Inhalation**

Assess the risks of the materials to be formed prior to use. Make sure to operate the machine in an adequately ventilated place.

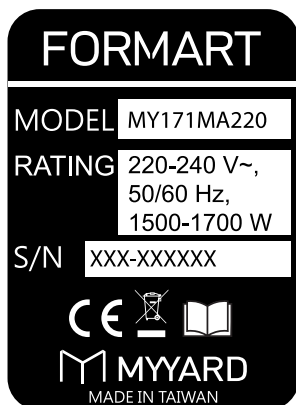

Check your supply voltage and frequency. Make sure it is compatible with this machine's specification plate next to the back power socket.



The heaters within the TOP UNIT can reach 280°C during heating. Never touch the heating element, heater case or heated plastics without wearing protective gloves to reduce the risk of burns.

# Handling Instructions for Delivery

---

- 1. Inspect Packaging Integrity**  
Before unpacking, check each package box for any visible damage or abnormalities. If any damage or deformation is noticed, please contact our customer service department immediately.
- 2. Unpack the Boxes**  
Carefully open each package box (PACK 1 and PACK 2). Use appropriate tools (such as scissors or a utility knife), but avoid applying force directly to the contents inside the packages.
- 3. Remove and Inspect Contents**  
Remove items from the boxes one by one and ensure all parts and accessories are complete. Refer to the parts list in the manual to verify each component.
- 4. Place the Equipment**  
Place the equipment on a stable, dry, and level work surface, ensuring there is ample space around it for installation and operation.
- 5. Dispose of Packaging Materials**  
Properly dispose of or recycle packaging materials (such as foam and plastic bags). Follow local recycling regulations for proper disposal.
- 6. Contact Customer Service**  
If you find any missing or damaged parts, please contact our customer service department immediately. We will provide the necessary support and assistance.

# Introduction

---

FORMART is a smart Vacuum Forming Machine which produces high definition mouldings in up to 3mm thick plastic sheet. FORMART is ideal for prototype development or small volume production.

## Main Features

- Automatic sheet detection
- Capable of using 4 different sheet sizes
- Heater auto shut-off after idle period
- Auto release mold function
- Plastic sheet dehumidification function

## FORMART Parts List:



Bottom Unit x 1



Top Unit x 1



Stainless Tube x 4



Size Adjustment Kit



Forming beds



Protective cover



Screw & Tool



Cat bowl mold

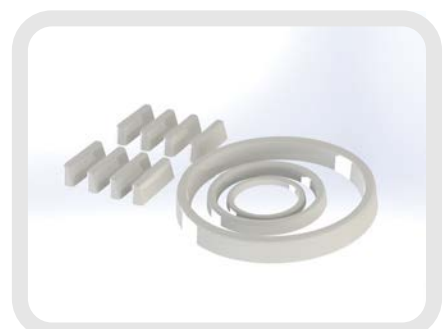

Webbing Remover Kit

# Machine Setup

## Machine Setup Guide

Please follow the instructions below to set up your FORMART.



Step 1: Align the tube hole and assemble the 4 tubes by turning clockwise until tightened



Step 2: Align the top unit with the tubes and put it on



Step 3: Fasten screws of top unit



Step 4: Plug in heater wires

# Machine Setup



Step 5: Assemble protective cover with screws



Step 6: put on the forming beds on the top of bottom unit

## Warning!

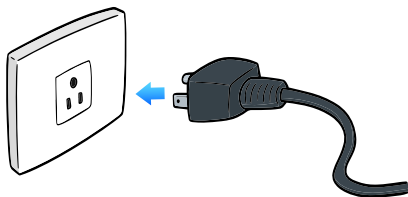

Make sure the plug is fully inserted

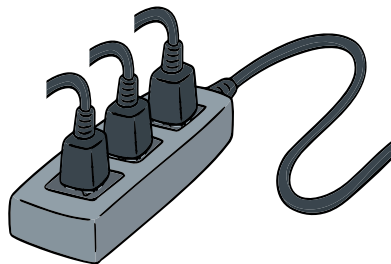

Do not share power extension cord



Do not place objects on top of FORMART

# Machine Introduction

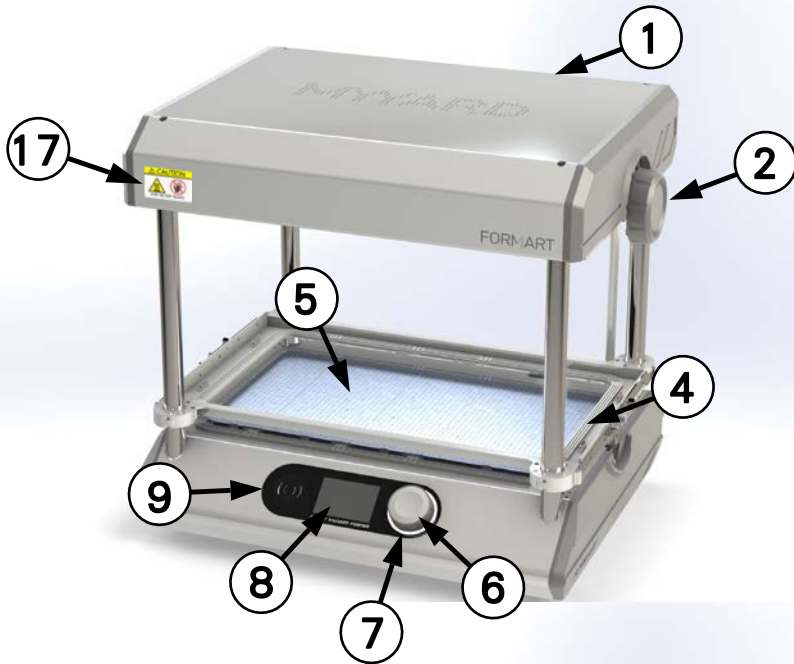

1. Heater
2. Side wheel
3. Top frame
4. Bottom frame
5. Forming beds
6. Navigation controller
7. Status LED ring
8. LCD display
9. Speaker
10. Fan
11. LED light
12. IR sensor
13. USB connector
14. Fuseless protector
15. Power switch
16. Sheet detector
17. Warning label

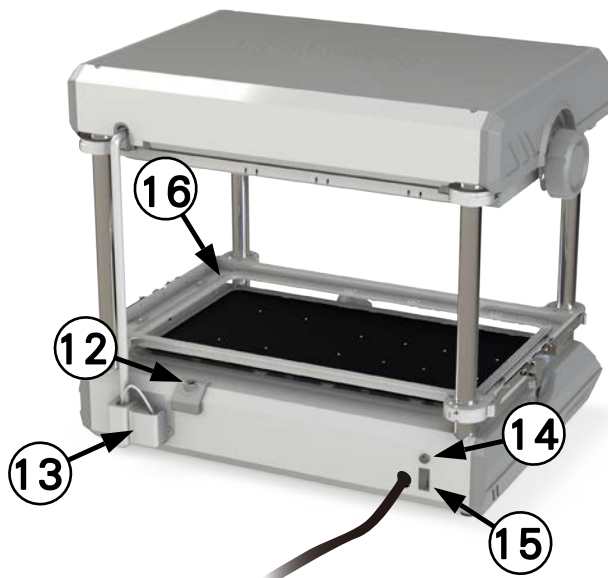
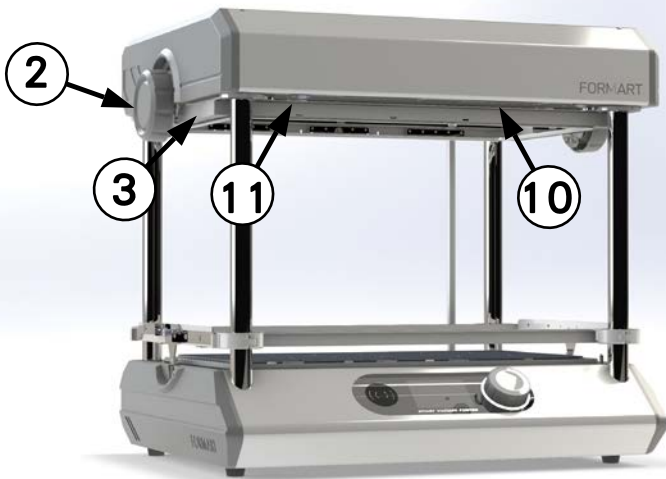

## Current Protector

The machine is protected with 8A fuseless current protector. In case of a blown fuse, please do not reset it before consulting service.

## ON/OFF switch

The main power switch to provide power to FORMART.

# Basic Operation

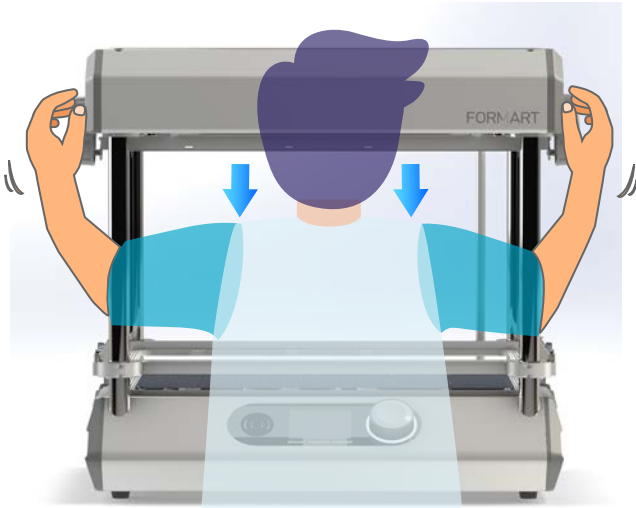

## Top frame operation

FORMART top frame is held by magnets, once it is released from the top, it will slide smoothly on the steel rails. Be sure to support the frame with both hands when pulling downward to avoid excessive impact to the bottom frame.

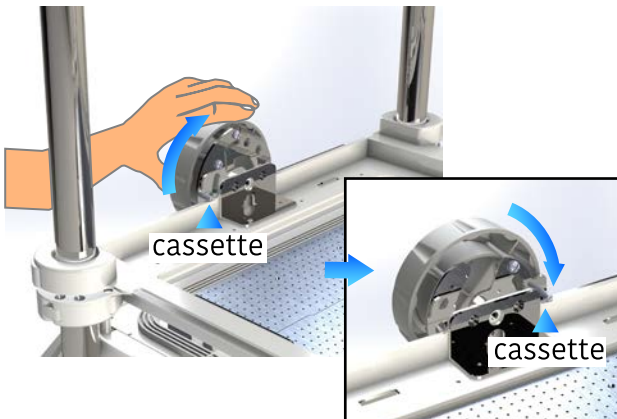

## Sheet locker

Plastic sheet is secured in place by two side wheels. Turn forward to lock the sheet and turn back to release.

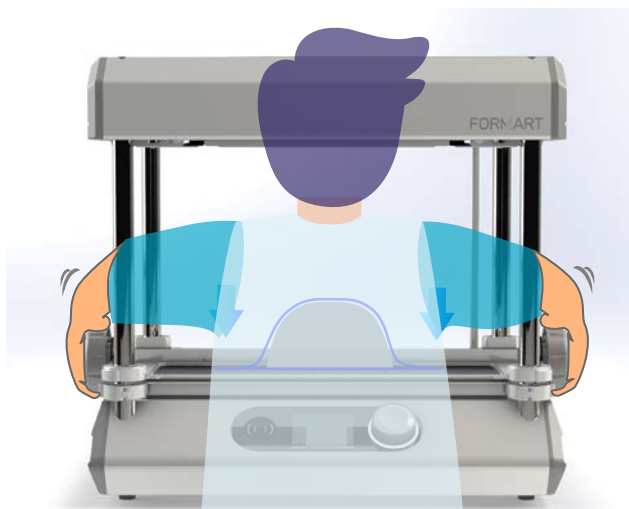

## Frame down to form

When preparing the frame for forming, gently press the frames to the bottom and wait 3 seconds before releasing your hands. Please do not use excessive force on the frame to avoid damaging the machine.



## Emergency stop

The main operation knob is also an emergency stop button. Simply press the main knob whenever you want to cancel the task.

# Basic Operation

## Switch Sheet Size



**HOT!**

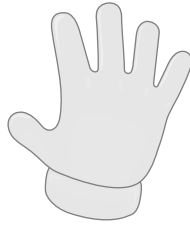

**Glove Required!**

- Bottom Frame: Put the bottom adjustment plate into the notch of the bottom frame

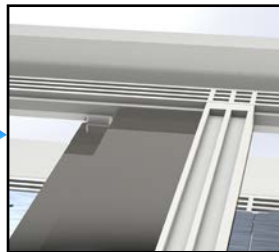
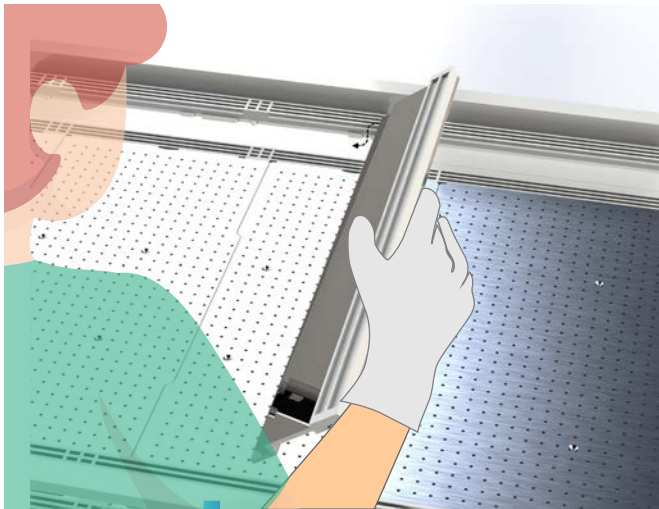

- Top Frame: Put the top adjustment rod into the notch of the top frame

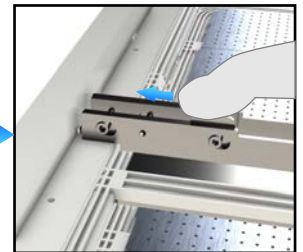
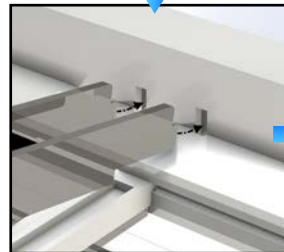
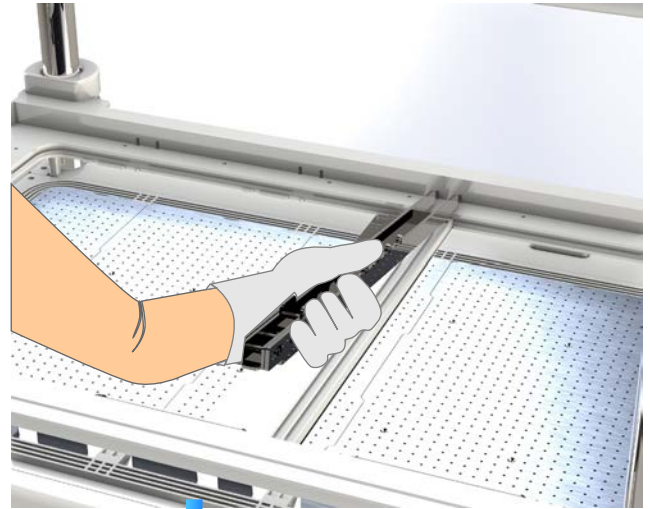

Please remember to **remove the forming bed** that below the adjustment plate, or the frame may be damaged from operation

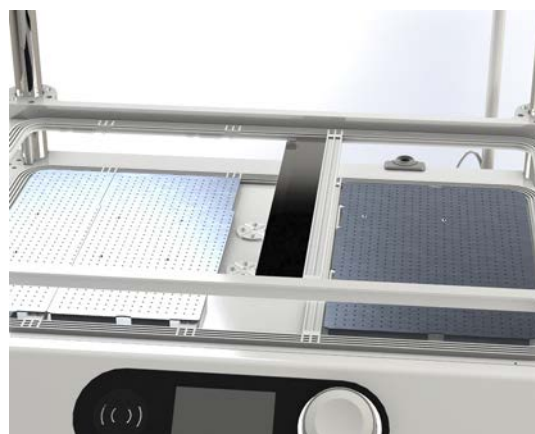
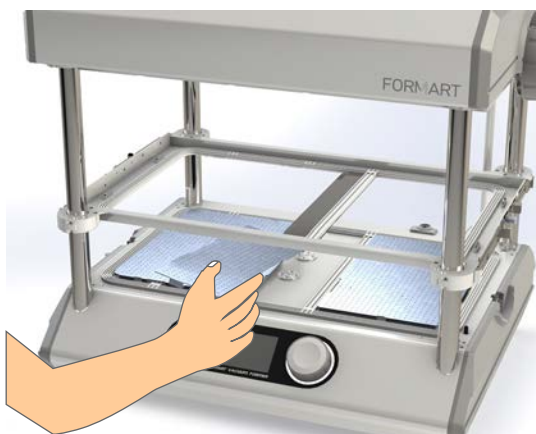

# Operation Procedure

---

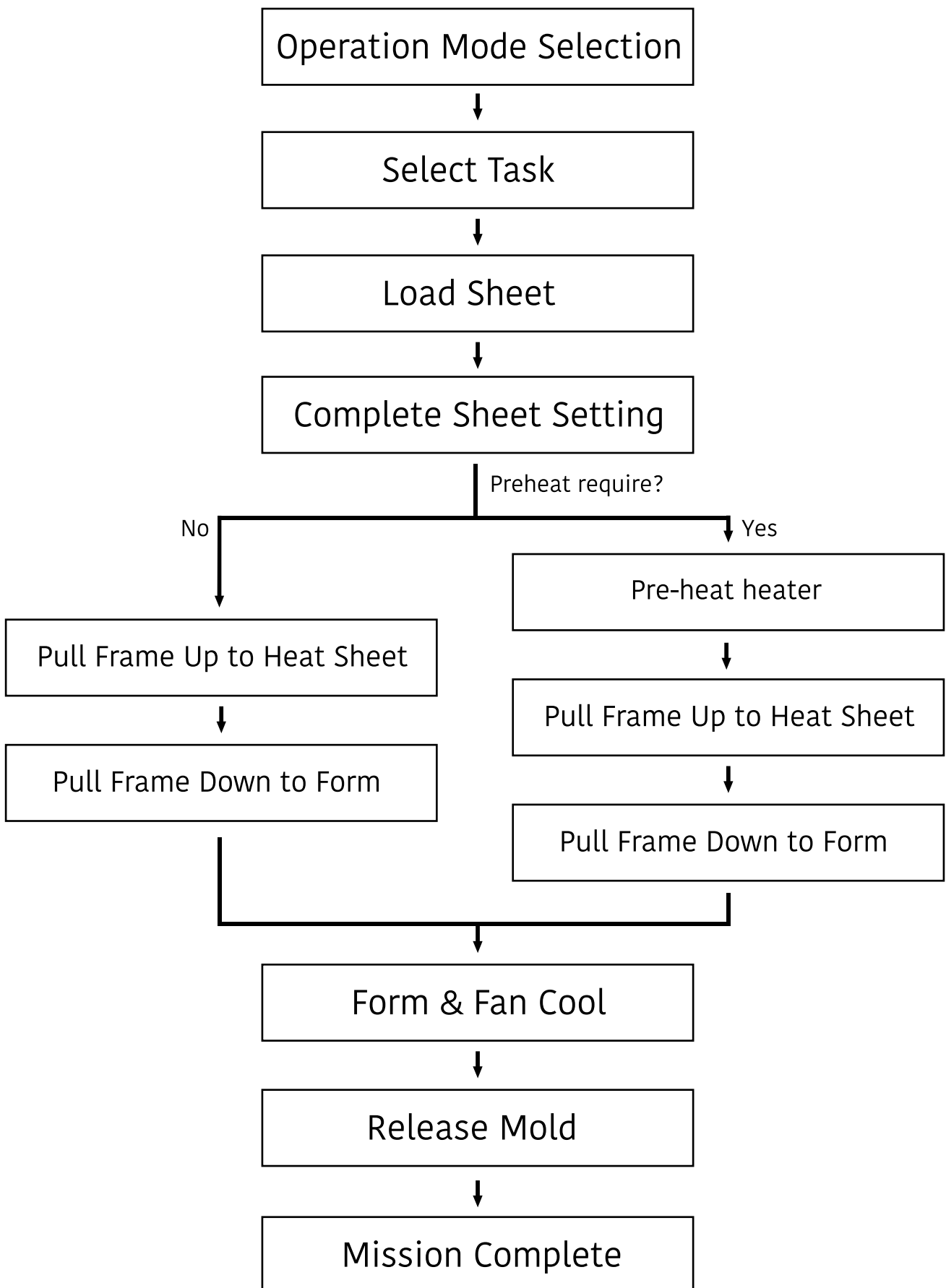

# Operation Procedure

## Select Operation Mode & Task

FORMART provides two operation modes. **Simple mode** & **Advanced mode**. Rotate the knob to move selection between modes and **press** to confirm.



### Simple Mode

The mode is suitable for beginners. With this mode you can form objects by default without dealing with complicated settings.



### Advanced Mode

The mode is suitable for professionals. It allows revisions of most settings, including heating curves & forming pressure.



### Select Task

Turn knob to select between different tasks.

- Rough: form object with lowest pressure
- Standard: form object with meddium pressure
- Fine: form object with highest pressure
- Dehumid: to dehumidify plastic sheet



### Load Sheet

If using an original FORMART sheet, please load the sheet into the frame and align the QR-code to the front right corner.

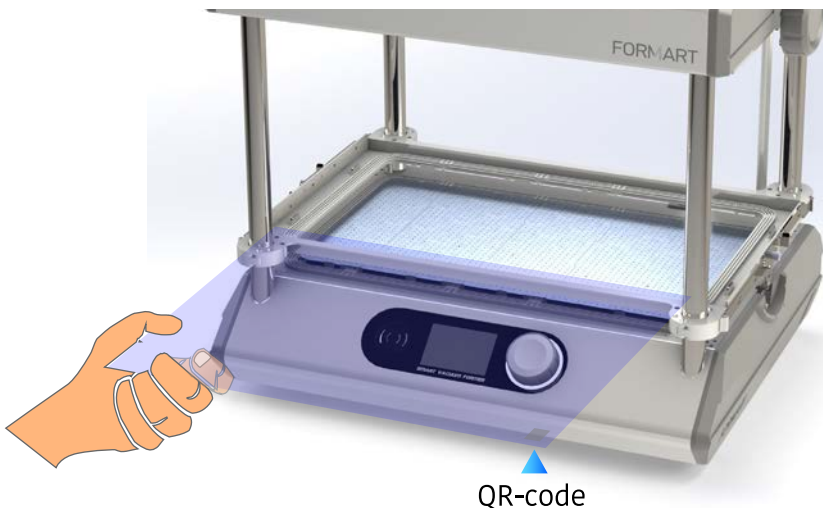

If the sheet is detected, FORMART will load corresponding parameters automatically.

(If you are using non-original sheet, please turn the knob to **Material** then press & rotate to select your material. Then FORMART will load corresponding parameters. Repeat above step to set the sheet **Thickness**.)

# Operation Procedure

## Simple mode



Set Complete



Some sheet materials may require preheating before heating the plastic sheet. Please wait until the heater achieves target temperature.



Pull the frame down toward the forming bed and secure the sheet in the frame by turning the side wheels forward until they lock. Then pull the frame up to attach it to the top magnet.



Start heating the sheet to its target temperature. During this period, please load the mold on the forming bed.



When the sheet has reached its target temperature, quickly pull the frame down to form over your mold. (Must pull down within 3 seconds if using PET sheet)

## Advance mode



Advance Set.



Within advanced settings, you can edit configurations:

- 1.LCD bri.: Change LCD brightness
- 2.FAN SW: Cooling FAN on or Off
- 3.RLS. mold: Release mold function on or off
- 4/5/6.: Edit Rough/Standard/Fine mode forming pressure



- 7.Heater setting:
  - 7-1.Preheat: Switch heater pre-heating ON or OFF
  - 7-2.Heating curves: To change heating curves A,B,C



Curve A:  
Heating sheet in linear curve

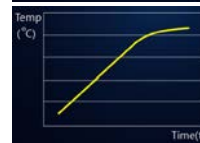

Curve B:  
Heating sheet in parabolic curve



Curve C:  
Heating sheet in step curve

Tune (1~9): To modify heating speed. Higher value will result in longer heating time.

# Operation Procedure

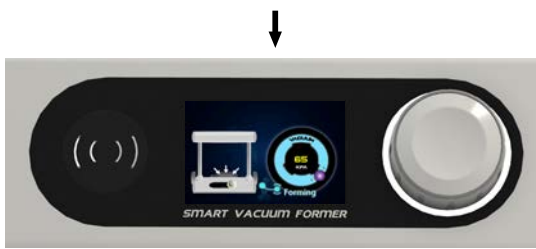

Form blister and showing pressure



Cooling Blister

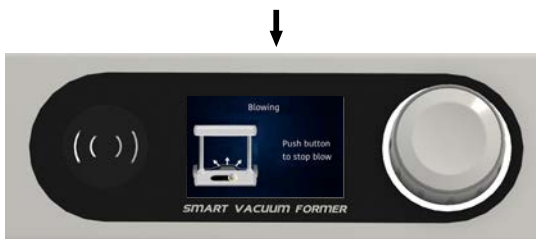

Blower automatically engages to release mold. You may slightly slap the blister to help release the mold. Press knob to stop the blower.



Task finished. Press to restart.

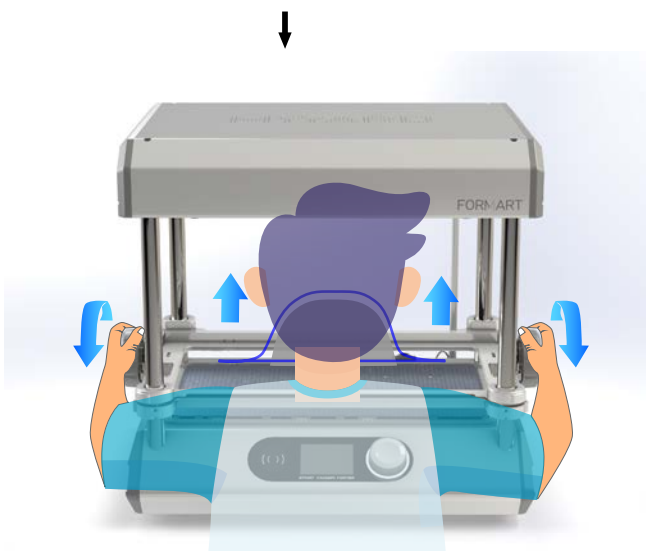

Turn side wheels backward to release finished blister and pull the top frame up and repeat for the next task.

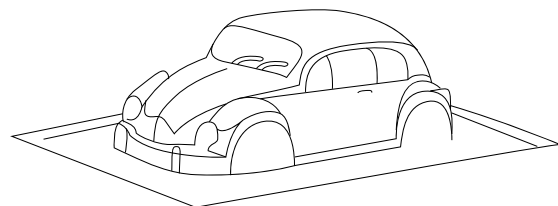

# Accessory Instructions

## Cat bowl mold

In the accessory box, you will find a cat bowl mold and a nose cap as a reference for your vacuum mold design. You can use the mold to make blisters and compare the results between wearing the nose cap and not wearing it.



Without nose

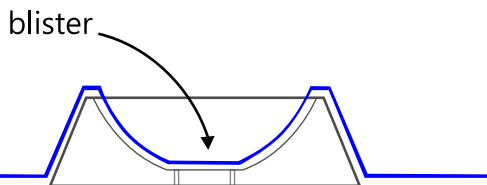
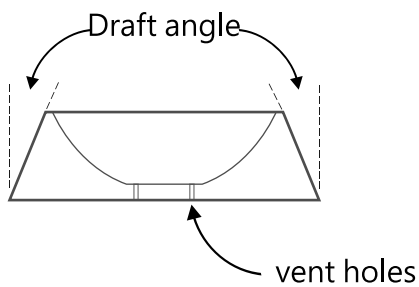

The blister forms smoothly including the center hollow



With nose

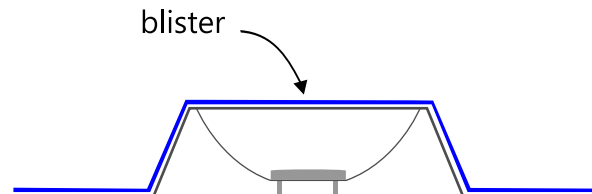
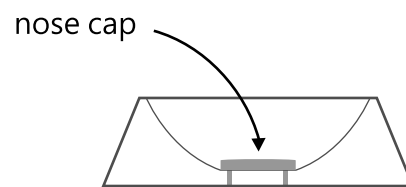

Nose cap blocks the vent holes and the center hollow cannot be formed

1. When you design a vacuum mold, the draft angle must be larger than  $3^\circ$  to ensure the mold can be easily released out of the blister.
2. Please remember to leave vent holes in the recesses of the mold.

# Accessory Instructions

## Webbing remover

Webbing problem is the most common phenomenon during vacuum forming, especially at corners or taller shapes.



Corner Webbing



Tall Shape Webbing

### 1. Webbing remover cubes

Place the webbing removing cubes in the proper place to minimize corner webbing.

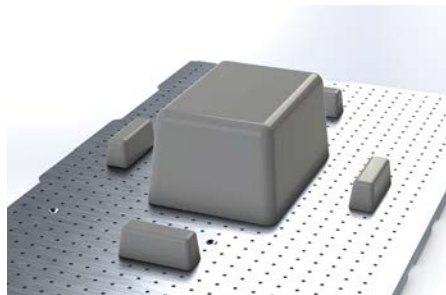

### 2. Webbing remover collars

Place your mold in the center of the webbing removing collar to minimize webbing.

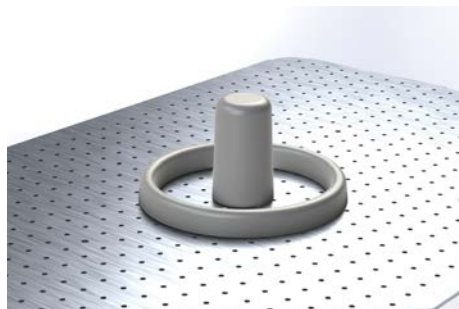

\*Those webbing cubes & collars are provided as potential solutions for solving the webbing issues you may encounter. Larger objects may require additional cubes/collars(not provided).

# Accessory Instructions



Volume Control Kit(Optional - Purchased Separately)  
It is used to eliminate the webbing between two molds.

Scan QR code to see video instruction



Please follow below steps to setup the volume control kit

(Figure 1) Please install S27 & S28 in the appropriate place as shown below.

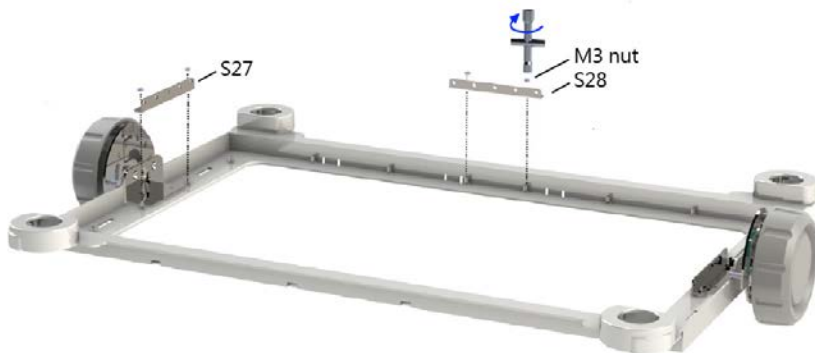

(Figure 2) Please insert steels S29 & S30 into the holes where the webbing phenomenon appeared.

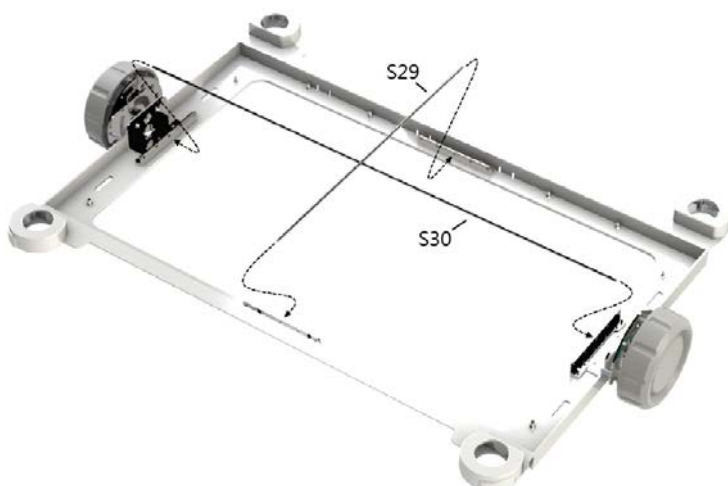

# Maintenance

---

1. Ensure the surface of the machine and the heater surround is free of dust, dirt and debris.
2. Please clean the air filter regularly.

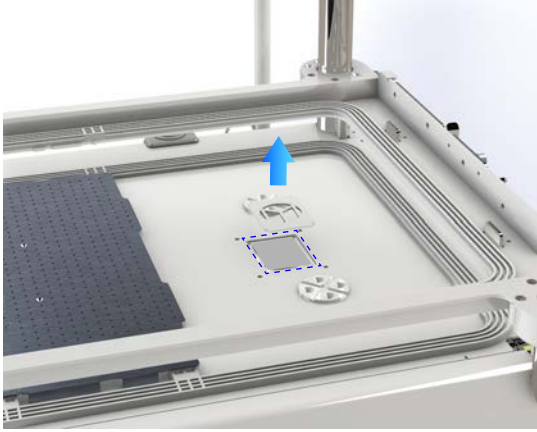

3. FORMART's 4 steel tubes (frame rails) DO NOT require any lubrication. **Please DO NOT apply any lubricants of on the 4 tubes.**
4. In case of FORMART failure, we may require you to return defect unit. However, Please DO NOT disassemble any independent module other wise the warranty may invalid.

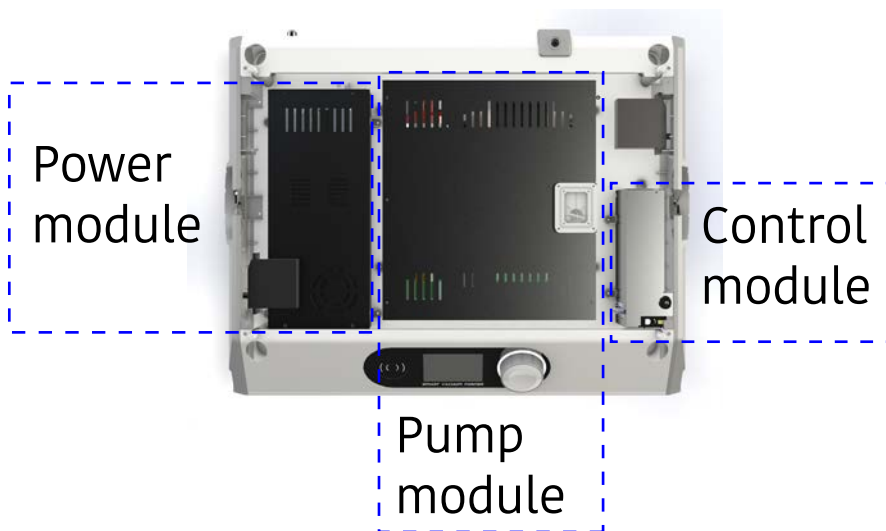

5. If the supply cord is damaged, it must be replaced by the manufacturer, its service agent or similarly qualified persons in order to avoid a hazard.

# Machine Storage Instructions

---

## 1. Storage Location

Store the machine in a clean, dry, and well-ventilated area. Avoid locations with high humidity, extreme temperatures, or direct sunlight.

## 2. Surface

Place the machine on a stable and level surface to prevent any tipping or instability. Ensure there is adequate space around the machine for safe handling and maintenance.

## 3. Protect from Dust and Debris

Cover the machine with a protective cover when not in use to prevent dust and debris accumulation. If a cover is not provided, consider using a clean, dry cloth or plastic sheet.

## 4. Avoid Heavy Loads

Do not place heavy objects on or near the machine. This can cause damage or affect its functionality.

## 5. Electrical Safety

Ensure that the machine is unplugged when not in use. Store the power cord and any other electrical components properly to avoid damage or accidental hazards.

## 6. Regular Inspections

Periodically check the machine for any signs of wear or damage. If any issues are detected, contact customer service for support.

## 7. Handling Precautions

When moving or relocating the machine, handle it with care and avoid any sudden impacts or drops that could cause damage.

# FAQs

---

Q: Why did my forming fail?

A: There are many reasons for forming failures. Please check if any of the following issues occur:

1. Confirm that the accessories are installed correctly:  
Check if the size switching accessory is properly installed, the size adjustment bar is securely latched, and the corresponding size venting base plate is removed. Improper installation of accessories can affect air sealing, leading to vacuum failure.
2. Check if the heating temperature is appropriate:  
Ensure that the plastic sheet used is a thermoplastic material and that the set temperature has reached the target before forming.
3. Vacuum setting:  
The vacuum level setting depends on the detail required in the finished mold. For packaging or natural stretch shapes, use a lower vacuum level. For detailed mold duplication, choose the fine mode.
4. Differences in material properties:  
Although most plastics can be thermoformed, different materials and brands have varying composition ratios, and even color can affect the temperature setting. For third-party sheets, use FORMART's built-in database to select the material, color, and thickness to reduce the chance of failure with the built-in heating parameters.
5. Proper vent holes in the mold:  
If the mold has recessed features, the recessed area must be drilled with appropriate extraction holes (1.5-2mm in diameter) to ensure correct forming.

Q: Why did my transparent PET sheet turn white after forming?

A: Whitening can occur if the PET is overheated or heated for too long. Reduce the heating temperature slightly and pull down the frame immediately after reaching the target temperature to avoid overheating.

Q: Why did I get webbings on the finished mold?

A: Webbings often occur at mold corners or with tall-shaped molds. Use our webbing remover kits to solve this problem:

- For corner webbing: Use the rectangular webbing remover around the corners of the mold and adjust the distance.

# FAQs

---

- For larger or specially shaped molds: Redesign the size or change the placement distance of the webbing remover for optimal results.

Q: Why does my mold look unclear?

A: High heating temperatures can cause surface bubbles, wire cracking, or whitening in some plastics like PET. Additionally, if the vacuum is set too high, the smoothness of the mold surface becomes crucial. Polishing the mold or treating its surface can solve this issue.

Q: Why are there small bubbles in the formed mold?

A: Bubbles can form if the material has absorbed moisture. Dry the material before molding. FORMART is the first machine with a built-in dehumidifier function, using the heater to warm the plastic sheet below 90°C to evaporate moisture before forming. This function is crucial in humid climates to reduce bubble formation.

Q: What objects can I use to mold?

A: You can use existing objects, 3D printed parts, etc. When designing the mold, consider the extraction angle ( $> 3^\circ$ ) for easy removal and ensure mold flatness. Avoid using molds with water or debris, which can damage the pump module. Always clean your object before molding.

Q: Will the mold be damaged?

A: The vacuum force exerts pressure on the mold. For thin-shell or fragile objects, add internal support structures to stabilize the forming process.

Q: Are there any restrictions on mold size and height?

A: FORMART can handle objects up to 160 mm in height, with a maximum forming area of 470 mm x 270 mm. Taller molds should have a moderate height-to-width ratio.

Q: Will 3D printed molds withstand high temperatures?

A: Although 3D printed products are not inherently heat-resistant, the thin plastic sheet cools quickly, minimizing damage. Our tests show:

- PLA printed products can be molded about 3-5 times.

# FAQs & Specifications

---

- Resin printed molds can withstand hundreds of uses.

For greater durability, after forming the first plastic shell, make a stronger mold by casting cement or plaster before starting production. Ensure the shell thickness of the 3D printed object is thicker than 1.5mm – the thicker, the better.

Q: Will the forming process produce toxic fumes or particles?

A: MYYARD materials are safe, non-toxic, and environmentally friendly. However, there may still be some smell during heating. Use the machine in a well-ventilated area. For third-party materials, check with your supplier to ensure compatibility with MYYARD machines. Some third-party materials may release toxic gases when heated, so avoid using the machine in confined spaces.

## Specifications:

Dimension	625(W) x 534(H) x 476(D)mm
Weight	25Kg
Input Power	220~240VAC@1700Watt
Display	3.5" 480*320 Full color LCD
Heater	Quartz Carbon Heater Tubes
Heating Range	90~230° C
Sheet Size	500 x 300mm; 420 x 300mm(A3); 300 x 300mm ; 300 x 205mm(A4)
Sheet Thickness	0.3~3.0mm
Pump	200W DC pump*1 80W AC pump*1
Suction Flow	>200L/MIN
Max. Vacuum	-90KPA(-10~-90KPA tunable)
Max. Draw	160mm Max.
Mold Weight	5Kg Max

# Warranty Terms

---

1. We provide a two years warranty under normal use on this machine. However, due to the differences of personal operating habits, the following parts are not covered by the warranty.
  - Rubber seals
  - Frames & sheet lockers
2. Due to the damage caused by the following cases, we will charge for the repair or maintenance.
  - Damaged by abnormal operation or exceeding the specification.
  - Damaged by incorrect voltage, falling, accidents or natural disasters.
  - Damaged by unauthorized disassembly.
  - Damaged by unauthorized repairs.
3. MY YARD TECH will pay the shipping costs for the repairs that meet above warranty terms. If repairs exceed those covered by the warranty, the buyer will need to pay the repair & shipping fees.
4. Warranty terms of service apply only to consumers who purchase our products through legal sales channels.
5. For counter-repair products, buyer should agree with us to replace the failed parts by using alternatives or used parts.
6. We do not authorize the use of this machine or its spare parts in life support equipment. We will not be held liable for any personal injury or death caused by the user's misuse of our product.

# Risk Information

---

From the initial design phase, FORMART has thoroughly considered user safety and implemented several safety measures. However, some risks cannot be entirely eliminated.

## 1. Implemented Safety Measures:

- Overcurrent circuit protection(Kuoyuh 88-08-A1B14-P00NB)
- Overvoltage protection(Meanwell LRS-350-24)
- Surge protection
- Software timeout protection

## 2. Residual Risks:

- Improper Operation Risk: Even with comprehensive safety mechanisms, if the operator does not follow the standard procedures, there is still a possibility of equipment damage or personal injury.
- Unexpected Hardware Failures: Although the equipment undergoes rigorous testing, unexpected hardware failures, such as motor overheating or electronic component failures, cannot be completely ruled out.
- Power Failure: FORMART is not subject to any damage or abnormality due to power outages. It will reset its internal programs and be ready for operation again when the power is restored. There is no residual risk from power outage.
- Environmental Factors: External environmental factors that are beyond our control, such as extreme weather or earthquakes, may impact the equipment.
- Software Errors: While we have software timeout protection, there is a minimal chance of unforeseen software errors that may cause the equipment to stop or encounter other issues.
- Improper Maintenance: If the user does not follow our maintenance recommendations for regular checks and upkeep, it may increase the risk of equipment failure.

## 3. Risk Management Recommendations:

- Regular Training: It is recommended to conduct regular training for operators to ensure they are familiar with the operation and safety regulations of the equipment.
- Regular Maintenance: Perform regular checks and maintenance

# Risk Information

---

according to the equipment maintenance manual, and replace worn parts promptly.

- Backup Measures: Prepare emergency plans when operating the equipment to respond quickly if any issues arise.

# EU Regulatory Compliance

---

FORMART complies with the following EU Directives and Standards to ensure safety, reliability, and performance:

## **Directives:**

- 2014/30/EU: Electromagnetic Compatibility (EMC) Directive
- 2014/35/EU: Low Voltage Directive (LVD)
- 2006/42/EC: Machinery Directive

## **Standards:**

- EN 61000-6-2:2005: Electromagnetic compatibility (EMC) – Part 6-2: Generic standards – Immunity for industrial environments
- EN IEC 61000-6-2:2019: Electromagnetic compatibility (EMC) – Part 6-2: Generic standards – Immunity for industrial environments
- EN 61000-6-4:2007/A1:2011: Electromagnetic compatibility (EMC) – Part 6-4: Generic standards – Emission standard for industrial environments
- EN 61000-3-2:2014: Electromagnetic compatibility (EMC) – Part 3-2: Limits – Limits for harmonic current emissions
- EN IEC 61000-3-2:2019: Electromagnetic compatibility (EMC) – Part 3-2: Limits – Limits for harmonic current emissions
- EN 61000-3-3:2013: Electromagnetic compatibility (EMC) – Part 3-3: Limits – Limitation of voltage changes, voltage fluctuations and flicker in public low-voltage supply systems
- EN 61000-3-3:2013/A1:2019: Electromagnetic compatibility (EMC) – Part 3-3: Limits – Limitation of voltage changes, voltage fluctuations and flicker in public low-voltage supply systems
- EN 60335-1:2012: Household and similar electrical appliances – Safety – Part 1: General requirements
  - EN 60335-1:2012/AC:2014
  - EN 60335-1:2012/A11:2014
  - EN 60335-1:2012/A13:2017
  - EN 60335-1:2012/A1:2019
  - EN 60335-1:2012/A14:2019
  - EN 60335-1:2012/A2:2019
  - EN ISO 12100:2010: Safety of machinery – General principles for design – Risk assessment and risk reduction

By adhering to these directives and standards, FORMART ensures compliance with essential health and safety requirements within the European Union.

# Waste Disposal and Recycling

---

To comply with environmental regulations and ensure proper disposal of our products, please follow below guidelines:

1. Disassembly and Handling:

- Prior to disposal, fully disassemble the desktop vacuum forming machine. This includes separating main materials such as metal, plastic, circuit boards, screens, and wires.
- Ensure proper sorting of materials for subsequent processing and recycling.

2. Material Recycling:

- Metal Components: Collect all metal components and deliver them to designated metal recycling points or recycling centers.
- Plastic Components: Gather all plastic components and deliver them to designated plastic recycling points or recycling centers.
- Electronic Parts: Including circuit boards, screens, and wires, please deliver these to electronic waste processing facilities for safe handling and recycling to prevent environmental and health hazards.

3. Environmentally Friendly Disposal:

- Do not dispose of the machine in regular trash bins or incinerators.
- If unsure about disposal methods, seek assistance from local government environmental departments or designated waste disposal centers.

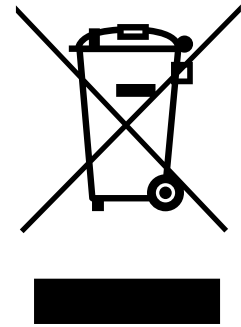

4. Professional Disassembly:

- It is recommended to have the desktop vacuum forming machine disassembled and handled by professional waste disposal companies or recycling centers to ensure compliance with local environmental standards and safety regulations.
- We are committed to environmental protection and resource recycling. Your cooperation will help minimize adverse impacts on the environment. Thank you for your support and cooperation!

For any questions or further guidance, please feel free to contact our customer service department.

Wechat ID  
@myyardtech

LINE@ ID  
@myyardtech

Facebook



466, Longnan Road, Pingzhen dist., Taoyuan 324027, Taiwan

**Manufacturer Information**

MY YARD TECH Co.,Ltd.